

DPF72002, DPF72003, DPF72004 Bilevel Step Motor Driver Packs

User's Guide



A N A H E I M A U T O M A T I O N

4985 E. Landon Drive Anaheim, CA 92807
e-mail: info@anaheimautomation.com

(714) 992-6990 fax: (714) 992-0471
website: www.anaheimautomation.com

DPF Driver Pack Features

- Two, Three or Four-Axis Packages
- Integrated 600 Watts Power Supply
- 10 Amperes/Phase Maximum Operating Current
- 7 Amperes/phase Standstill Motor Current
- Half-Step and Full-Step Operation
- Bilevel Drive Operation
- Unipolar Driver (6 or 8-lead motors)
- No RFI or EMI Problems
- TTL/CMOS Compatible Inputs
- Clock and Direction or Dual Clock Operation
- Motor Turn-Off Input

General Description

The Anaheim Automation DPF72002, DPF72003, DPF72004 Driver Packs are designed to operate 4-phase step motors rated at 1 - 7 amps/phase. These Driver Packs contain three or four BLD72 Step Motor Drivers, two 300 Watt transformers, and a cooling fan. Outstanding motor performance is provided by means of a Bilevel Drive technique.

Bilevel Drive

The basic function of a step motor driver is to control the motor winding currents. Motor performance is determined by how fast the driver can increase and decrease the winding currents. A rapid rise in winding current is achieved by applying a high voltage directly to a motor. This rapid rise of current is also referred to as the “kick” or operating current. When a desired current level is reached, a low voltage is applied to maintain a suitable holding current level. When a motor winding is turned off, a rapid decrease in winding current is achieved by routing the energy in the collapsing field back to the power supply through a high voltage path.

The high voltage supply furnishes the energy necessary to maintain motor output torque at high step rates thus providing high mechanical power output. The low voltage supply provides much of the current needed at low step rates and all of the holding current.

Bilevel drivers do not use high frequency switching techniques as chopper drivers do. Consequently, they do not create the EMI, RFI, and motor heating problems that are associated with choppers drivers.

Excitation Mode Select

Users have a choice of dual-phase, full-step operation or half-step operation. Dual-phase, full-step operation occurs by energizing two phases at a time, rotating a typical motor 1.8 degrees per step. Half-step operation occurs by alternately energizing one, and then two, phases at a time, rotating the motor 0.9 degrees per step. *Full-step operation is only suggested for applications that specifically require that mode, such as when retrofitting existing full-step systems.*

Step and Direction Control

The DPF72000 Series has two clock options: Clock and Direction, or Dual Clock operation. Terminal 5 can be configured as the Direction Input or CCW Input by placing jumpers in the appropriate positions (see Table 2). Pulses applied to the Clock input cause the motor to step in the clockwise direction if the Direction Input is a logic “1” or the counterclockwise direction if the Direction Input is a logic “0”. Pulses applied to the CCW Input cause the motor to step in the counterclockwise direction. Either positive or negative going pulses may be used by setting jumpers to the appropriate positions (See Table 2).

Motor ON/OFF Input

The motor on/off input allows for de-energizing a motor without disturbing the positioning logic. After re-energizing the motor, a routine can continue. This reduces motor heating and conserves power, especially in applications where motors are stopped for long periods and no holding torque is required.

DPF72002	2-Axis Driver Pack
DPF2003	3 Axis Driver Pack
DPF2004	4-Axis Driver Pack
BLD72	Replacement Driver

Adjusting Kick Current

By following the silkscreen markings on the cover, use a small screwdriver to adjust the potentiometer. Line up the arrow to the number corresponding to the motor’s rated current (amps/phase). This kick current is preset for 40 percent over the motor’s rated amps/phase.

Motor Connections

Figure 1 is a hookup diagram for typical DPF driver applications. All axes are wired the same (only one axis is shown). Wiring connected to inputs must be separated from motor connections and all other possible sources of interference.

Anaheim Automation offers color-coded shield step motor cable for easy hookups. This 16 gauge, 6 conductor cable is PVC insulated, with color-coded conductors, matching the leads on Anaheim Automation step motors. The cable is available in 25 feet increments, Part Number AA129010-S.

Important Note: When the wiring from the driver to the step motor extends beyond 50 feet, consult the factory.

Jumpers

There are several jumpers on the drivers. These jumpers are used to select positive or negative going clocks and to select clock and direction operation or dual clock operation. See Table 2.

XCE Versions

The DPF72000 Series Driver Packs are available in the XCE versions to accommodate power inputs other than the standard 115VAC. The XCE version can be configured to accept nominal power inputs of 100VAC, 115VAC, 130VAC, 215VAC, 230VAC, and 245VAC. Figure 3 shows connections to the power terminals for each configuration.

Specifications

Control Inputs (All):

(Terminals 5, 6, 8, 9)

TTL-CMOS Compatible

Logic "0" = 0-0.8V

Logic "1" = 3.5 to 5.0V

Clock Inputs: (Terminals 5 & 6)

15 microseconds minimum pulse width required. The Clock inputs are internally pulled down to 0VDC through a 10KU resistor for positive going Clock inputs or pulled up to +5VDC through a 10KU resistor for negative going Clock inputs.

Direction Control: (Terminal 5)

Pulled up to +5V through 10KU

Logic "1" (open) - CW motor direction

Logic "0" - CCW motor direction

Excitation Mode Select: (Terminal 8)

Pulled up to +5V through 10KU

Logic "1" - Half-Step

Logic "0" - 2 ÷ Full-Step

Motor On/Off: (Terminal 9)

Pulled up to +5V through 10KU

Logic "1" (open) - Motor Current on

Logic "0" - Motor Current off

Power Requirement:

Standard 115VAC version can accept power inputs ranging from 105VAC to 125VAC, 50-60Hz. See Figure 7 for power requirements for the XCE versions.

Operating Temperature:

0° to 60° C

The DPF Driver Packs contain an internal fan to create airflow through the unit. Heating considerations should include where the unit is mounted, the duty cycle of operation, ambient temperature, etc. Care should be taken so that no joint on the chassis exceeds 60 degrees Celsius.

Fuse Rating:

7 Amp Fast Blow, 5x20mm (this fuse is located in a slide-out tray just under the power receptacle)

7 Amp Fast Blow, 3AG for XCE Versions.

Troubleshooting

If a Fault occurs, reset the Fault by applying a logic “0” to the Reset Fault Input (terminal 4) for at least 100ms (or by cycling power OFF for at least 15 seconds). After resetting, try to run the motor again. If the driver faults again, then check the conditions listed below.

Is the LED Blinking Slowly?

This indicates that the motor has a phase shorted or there is a short in the motor cable or wiring. Check the motor and the wiring for shorts. If the driver continues to sense “shorts” after the motor and wiring are determined to be good, then the output transistors should be checked (see below).

Is the LED Blinking Quickly?

This indicates that there is an open connection in one of the motor wires. Check the motor and the wiring for opens. Another condition that may cause this type of fault, is when a large motor is ramped down to quickly so that it loses its positioning.

Is the LED on Steadily?

This indicates that there is a ground fault-a-voltage shorted to 0VDC. This detection is useful in detecting a short-to-case in a motor when the motor’s case AND the driver’s 0VDC are both connected to earth ground. Excessive noise on the 0VDC line may also cause the driver to sense this type of fault. This type of fault sensing may be disabled by placing jumper JP3 in position “1-2”

NOTE: IF THE GROUND FAULT DETECTION IS DISABLED, DO NOT CONNECT THE DRIVER’S 0V TO EARTH GROUND!

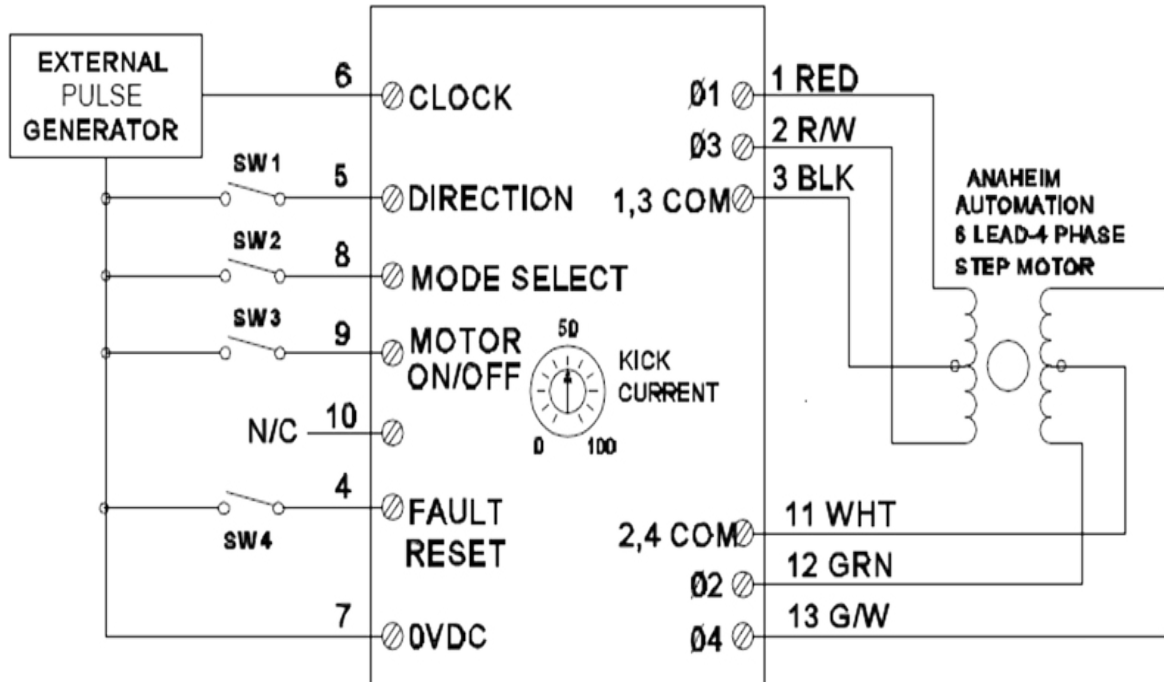

Dimensions

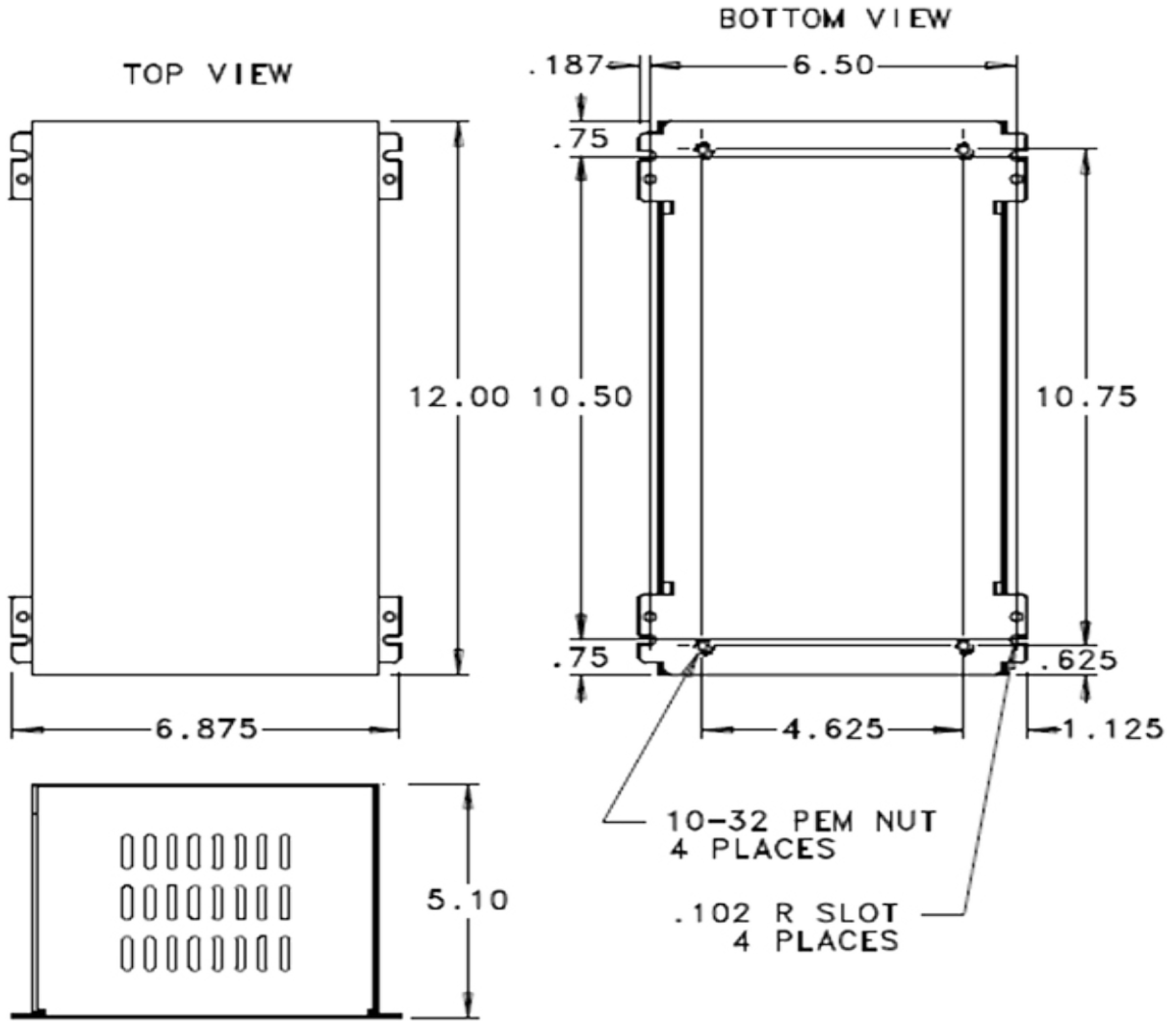

Torque Curves

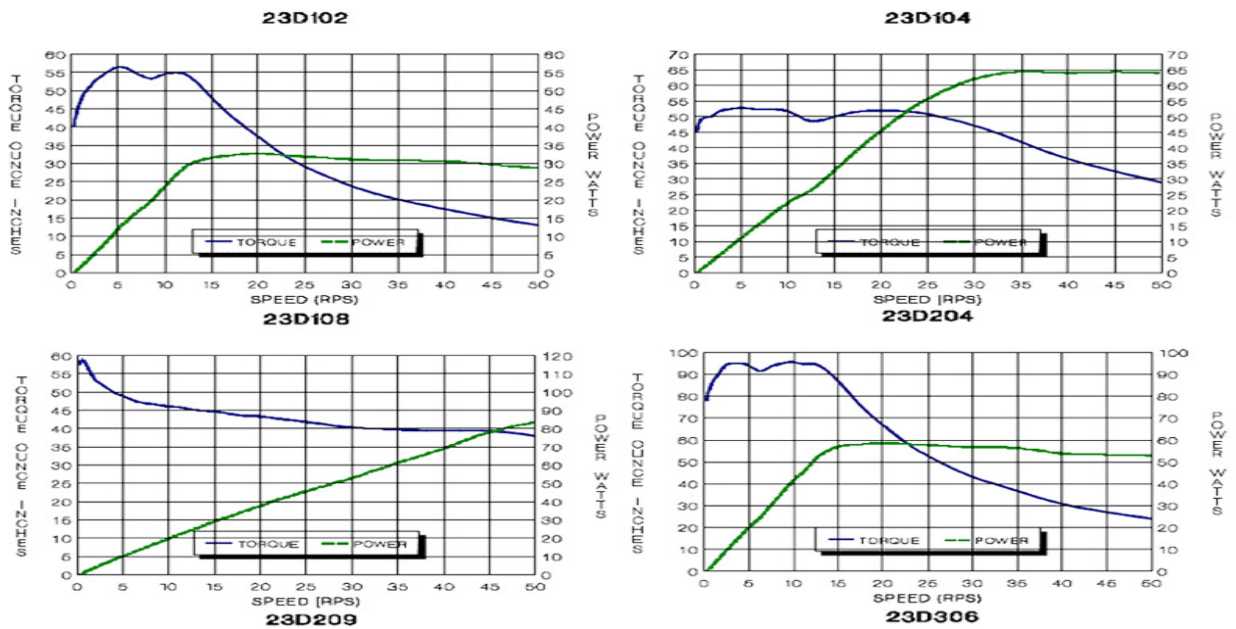

23D209

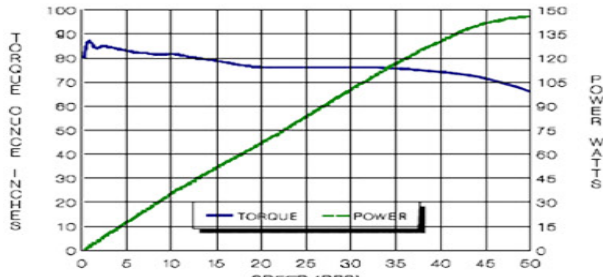

23D306

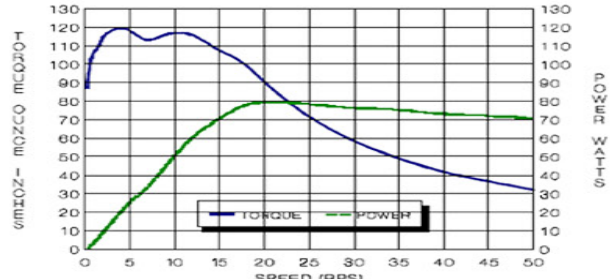

23D309

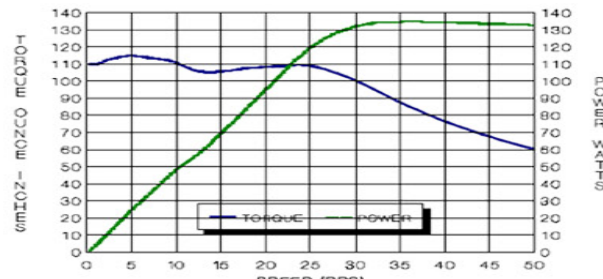

34D106

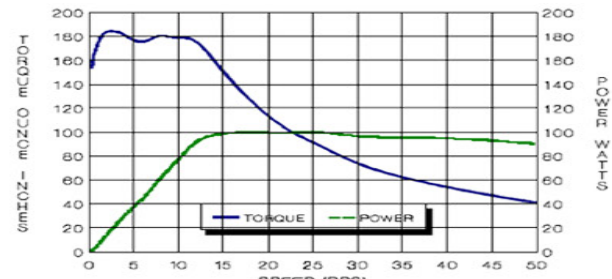

34D109

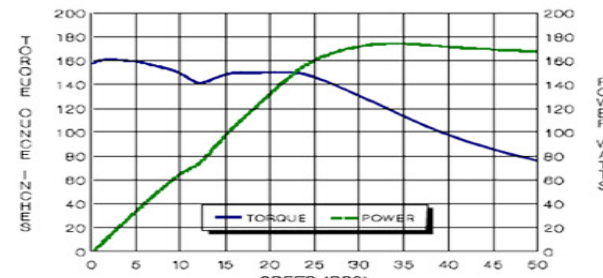

34D207

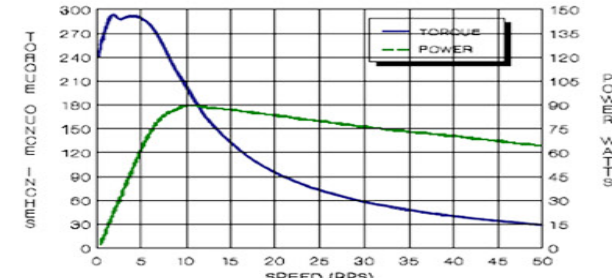

34D209

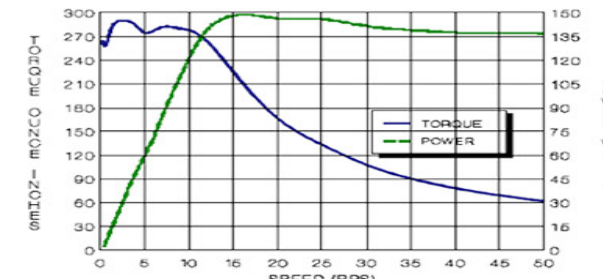

34D213

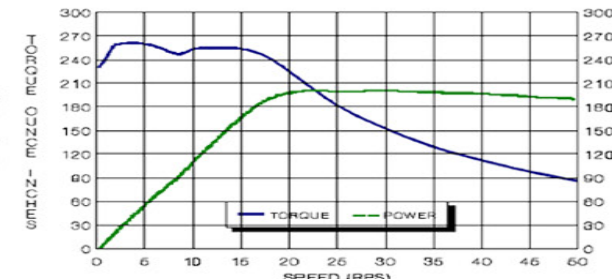

34D307

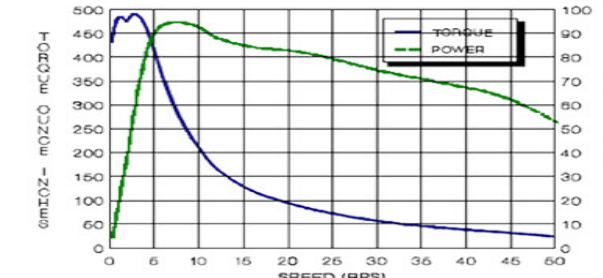

34D311

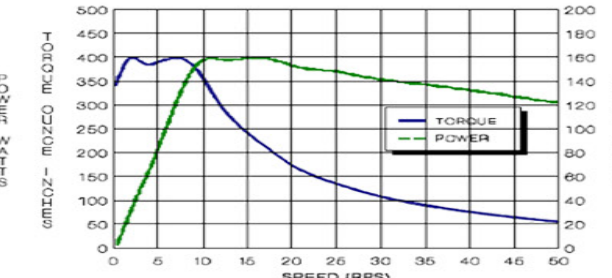

COPYRIGHT

Copyright 2007 by Anaheim Automation. All rights reserved. No part of this publication may be reproduced, transmitted, transcribed, stored in a retrieval system, or translated into any language, in any form or by any means, electronic, mechanical, magnetic, optical, chemical, manual, or otherwise, without the prior written permission of Anaheim Automation, 4985 E Landon Drive, Anaheim, CA 92807.

DISCLAIMER

Though every effort has been made to supply complete and accurate information in this manual, the contents are subject to change without notice or obligation to inform the buyer. **In no event will Anaheim Automation be liable for direct, indirect, special, incidental, or consequential damages arising out of the use or inability to use the product or documentation.**

Anaheim Automation's general policy does not recommend the use of its' products in life support applications wherein a failure or malfunction of the product may directly threaten life or injury. Per Anaheim Automation's Terms and Conditions, the user of Anaheim Automation products in life support applications assumes all risks of such use and indemnifies Anaheim Automation against all damages.

LIMITED WARRANTY

All Anaheim Automation products are warranted against defects in workmanship, materials and construction, when used under Normal Operating Conditions and when used in accordance with specifications. This warranty shall be in effect for a period of twelve months from the date of purchase or eighteen months from the date of manufacture, whichever comes first. **Warranty provisions may be voided if products are subjected to physical modifications, damage, abuse, or misuse.**

Anaheim Automation will repair or replace at its' option, any product which has been found to be defective and is within the warranty period, provided that the item is shipped freight prepaid, with previous authorization (RMA#) to Anaheim Automation's plant in Anaheim, California.

TECHNICAL SUPPORT

If you should require technical support or if you have problems using any of the equipment covered by this manual, please read the manual completely to see if it will answer the questions you have. If you need assistance beyond what this manual can provide, contact your Local Distributor where you purchased the unit, or contact the factory direct.

ANAHEIM AUTOMATION